

SHOE TYPE DC FAIL SAFE BRAKE

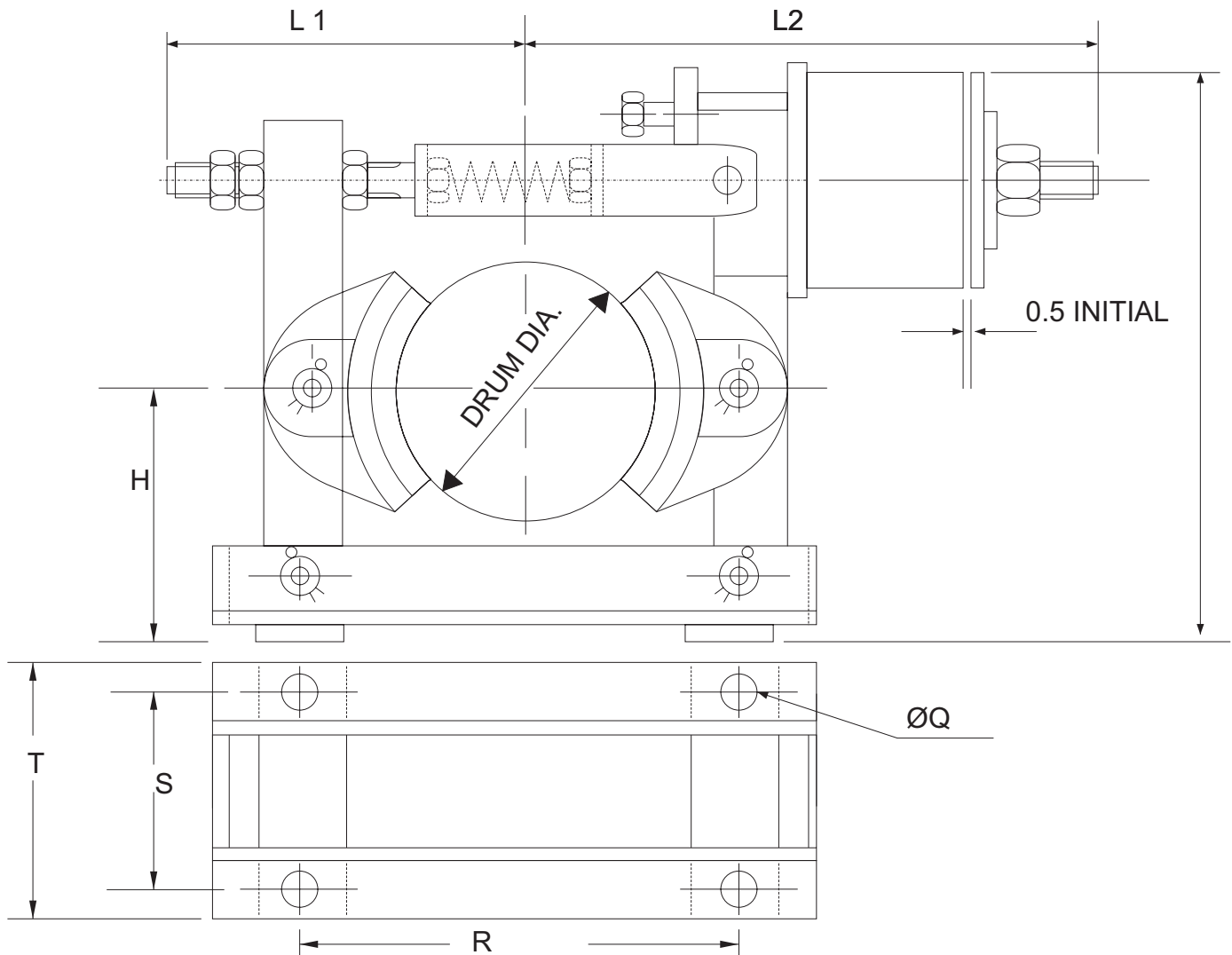

MODEL	40% C.D.F. TORQUE KG.M.	VOLTAGE V.DC.	WATTS	DRUM DIA.	SHOE WIDTH	H	Ø Q	R	S	T	V	L1	L2
DC-100	2	24	30	100	58	130	10	230	60	95	275	150	235
DC-150	6	24	30	150	70	150	14	310	60	95	328	168	290
DC-200	13	24	70	200	90	170	14	370	60	120	355	225	405
DC-250	20	24	70	250	110	200	14	440	70	130	425	255	440
DC-300	35	24	100	300	140	240	18	530	80	130	480	305	515
DC-400	75	24/190	200	400	180	320	18	640	100	260	690	265	720

- NOTE : 1 WE RESERVE OUR RIGHTS TO CHANGE ANY DIMENSION WITHOUT PRIOR NOTICE
2. NEAREST INCH SIZE SHOE BRAKE AVAILABLE ON REQUEST WITH SAME PRICE.
3. ALL DIMENSION ARE IN mm UNLESS AND OTHERWISE STATED.
4. TORQUE SHOWN IS NORMAL TORQUE. ACTUAL TORQUE IS MORE OR LESS DEPENDING UPON LINER, DUTY CYCLE, NUMBER OF ON AND OFF, LIVER RATION ETC.